



# ATLANTA

## Documented Procedure

### BWL 070e

### 4100-001-12.93

Department	TB/Wes	Operating and Maintenance Instructions Non-rotating trapezoidal thread spindle	Page	1	7
Modifi.Index	D		Name	Steinbach	22.11.06
Date	25.07.2013		Released		

### Translation from german original

## **ATLANTA High Thrust Linear Actuator EH8 with non-rotating trapezoidal-thread spindle Tr 80x10**

ATLANTA Antriebssysteme  
Eugen Seidenspinner GmbH & Co. KG  
Postfach 1161  
74301 Bietigheim-Bissingen

**The operating and maintenance instructions are to be strictly observed in order to ensure the proper functioning of the equipment and the acceptance of possible claims under warranty.  
Therefore you should carefully read these instructions before starting work with the Lifting Spindle Drive!**

**The instructions contain important information regarding the maintenance and should therefore always be kept near the Lifting Spindle Drive.**

### **Product description**

The High Thrust Linear Actuator EH8 with non-rotating trapezoidal-thread spindle consists of the following components: two-stage cylindrical gear unit, trapezoidal-thread spindle, trapezoidal thread nut (installed in gear unit), safety grip nut with automatic cut-off in case of breakage of the supporting nut, protective tube, bellows, link rod head, three-phase AC motor, limit switches at the protective tube, and electronically controlled lubricator.

Depending upon certain customer-specific modifications individual components may vary or be inapplicable.

### **General technical data:**

Trapezoidal-thread spindle	Tr 80x10
Nominal axial force of spindle	100 kN
Duty cycle	0-30% (dep. upon spindle force)
Type of load	push and pull
Travelling distance at spindle	> 20 000 m
Permissible static load	200 kN
Travelling speed	16 mm/s at 1400 rpm motor speed and ratio 15.18
Required input power	6.8 kW at 1400 rpm motor speed, 100 kN spindle force and ratio 14.18
Gear ratio	5.64, 6.90, 8.56, 10.85 or 14.18
Max. gear output torque	600 Nm
Self-locking acc. to VBG 14 with sufficient spindle lubrication.	



# ATLANTA

## BWL 070e

### Documented Procedure

### 4100-001-12.93

Department	TB/Wes	<b>Operating and Maintenance Instructions Non-rotating trapezoidal thread spindle</b>	Page	2	7
Modifi.Index	D		Name	Steinbach	22.11.06
Date	25.07.2013		Released		

**Installation, connection, start-up as well as maintenance and repair work may be carried out only by qualified personnel and with due regard to**

- these instructions
- the warning and information signs on the lifting unit
- any other project information, start-up instructions and circuit diagrams
- the unit-specific instructions and requirements
- the applicable national / regional regulations.

#### **Universally valid data for axial force of spindle and duty cycle:**

Precise data see order specific operating and maintenance instructions.

permissible axial force of spindle	Duty cycle related to 10 min.
100 kN	0 % ⇒ infrequent operation
80 kN	2 %
70 kN	3 %
60 kN	5 %

#### **Mounting**

Make sure to cover the contact surfaces of the radial shaft seals before painting the gear unit. The radial seals are located on both sides of the trapezoidal thread nut in which the spindle is installed and in the driving flange to which the motor is attached.

The gear unit is supplied preassembled. Check all screwed connections before mounting. The attachment to the lifting table or machine must be stress-free and free from transverse forces. The working surface of the trapezoidal thread must be carefully greased before starting up.

*A T L A N T A* suggestion: Klüber Nontrop KR29 BBM 450 EP

Or: Klüber Grafloscon C-SG Ultra 1000

#### **Mechanical startup**

Motorized lifting spindle drives are generally designed for intermittent operation. It is therefore important that the specific cycle times acc. to design as well as the lubricating instructions are strictly observed when starting up the unit for the first time and also during operation. The cycle times are mentioned in the order specific operating and maintenance instructions. Otherwise the above listed data is valid.

The motor driven operation of the gear unit without end-position control (limit switch at protective tube) is not permissible because overshooting the end-positions will cause mechanical damage to spindle and gear unit. For test runs of the uninstalled gear unit it is necessary to support the torque at the spindle by suitable measures.



# ATLANTA

## BWL 070e

### Documented Procedure

### 4100-001-12.93

Department	TB/Wes
Modifi.Index	D
Date	25.07.2013

**Operating and Maintenance Instructions**  
**Non-rotating trapezoidal thread spindle**

Page	3	7
Name	Steinbach	22.11.06
Released		

#### End positions :

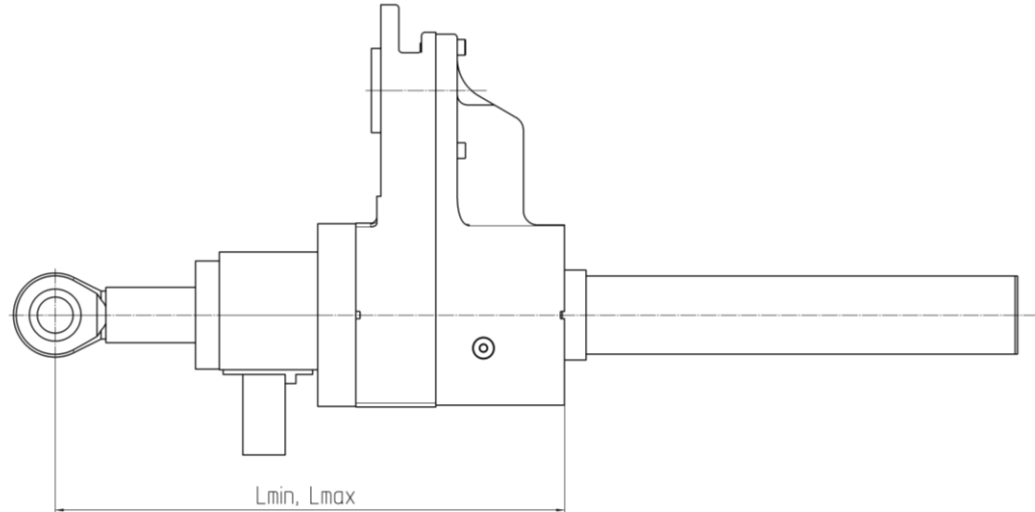
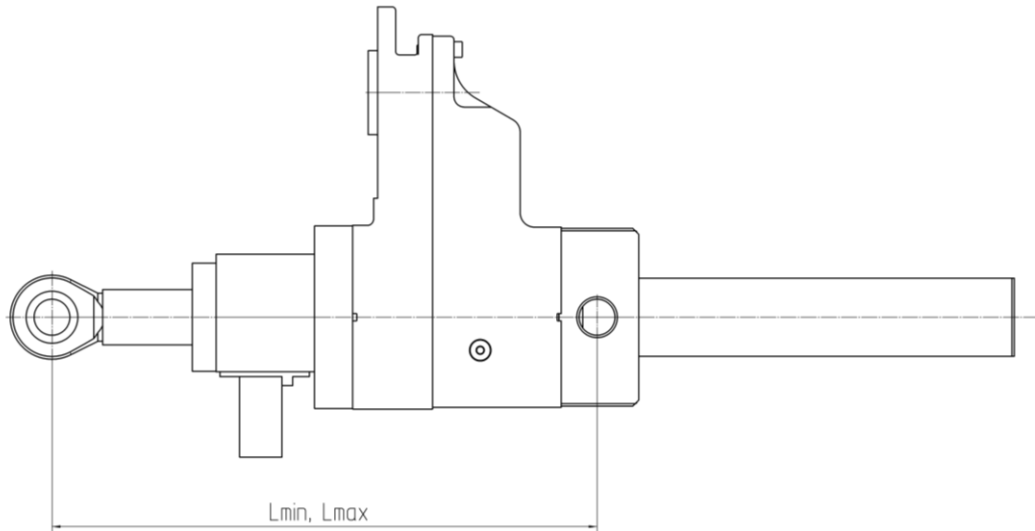

 **ATLANTA** Antriebssysteme

Max. Hub = ...mm  
Lmin = ...mm  
Lmax = ... mm

Max. Hub = maximum permissible stroke  
L min = minimum length in retracted position; may not be less  
L max = maximum length in extended position; may not be more



# ATLANTA

## Documented Procedure

### BWL 070e

### 4100-001-12.93

Department	TB/Wes	<b>Operating and Maintenance Instructions Non-rotating trapezoidal thread spindle</b>	Page	4	7
Modifi.Index	D		Name	Steinbach	22.11.06
Date	25.07.2013		Released		

### Electrical startup

**All electrical components are to be connected only by specially trained skilled personnel. The attached operating and maintenance instructions of the motor and/or the technical data sheets of the two limit switches must be strictly observed.**

Connect the limit switches at the break contacts 11 and 12 in order to ensure the forced mechanical disconnection of the break contacts.

Check the limit switches at the protective tube for proper function and correct position.

The power connection for direct mains operation is shown on the enclosed connecting diagram.

In order to protect the brake control from disturbing influences the brake lines must not be installed together with clock-pulse controlled power lines in one cable.

In order to protect the motor protection devices (temperature sensors, coil thermostats) from disturbing influences unshielded supply lines must not be installed together with clock-pulse controlled power lines in one cable.

**It must be ensured that an overload protection device limits the motor torque to 150 % of the motor torque when lifting the nominal load.**

**In the case of motors powered by frequency converters it is absolutely necessary to observe the frequency converter manufacturer's operating and maintenance instructions as well as the wiring instructions.**

**We strongly recommend to provide S-shaped ramps at the converter.**

### **Lubricating Instructions**

The sliding friction prevailing between the trapezoidal-thread spindle and nut makes it absolutely necessary to ensure sufficient lubrication. Without adequate lubrication there will be excessive wear and tear leading to the destruction of the nut.

The electronically controlled lubricator is to be put into operation as described in the enclosed instruction.

The trapezoidal-thread spindle is supplied with an initial lubrication sufficient for approx. 10 strokes.

For putting the unit into operation, the hose should be filled before mounting by means of a grease gun.

Proper lubrication is ensured only when the connecting hose is completely filled with grease right into the nut.

For pressure buildup observe the times indicated in the lubricator operating instructions.

Quickest pressure buildup: all switches „ON“. Pressure buildup within 6-8 hours.

Type of lubricant: NONTROP KR29 BBM 450 EP (Klüber) ATLANTA no. 9 90 04 009

or: Grafloscon C-SG 1000 Ultra (Klüber) ATLANTA no. 9 90 04 018

Based upon our tests, we recommend to set an emptying time of 6 months after the startup and the pressure buildup. During the first days and weeks the lubricant supply should be checked at regular intervals and the emptying time should be adjusted to the application. The spindle surface must always be covered with a uniform, thin grease film.

Grease in the protecting tube or under the bellows is an indication for an excessive lubricant supply.

Screeching noises between spindle and nut are an indication for insufficient lubrication.

The level in the lubricator should be checked regularly. We recommend to include this check in a maintenance plan.

When the lubricator is completely empty it can be used again after refilling. Only the pressure chamber where the gas generation takes place and which is available as a spare part must be replaced. A permanent signal lamp powered by two commercially available 1.5 V batteries shows that the lubricator is ready for use. Please ask for our relevant instructions BK1 103.

With a view to the grease consistence of Nontrop KR29 BBM 450 EP from Klüber we recommend to take special care when refilling the lubricator that no air bubbles are trapped in the lubricator. They might be the reason for insufficient lubrication when they are transported to the lubricating spot.

**No warranty will be assumed if the lubricating instructions are not observed.**



# ATLANTA

## BWL 070e

### Documented Procedure

### 4100-001-12.93

Department	TB/Wes	<b>Operating and Maintenance Instructions Non-rotating trapezoidal thread spindle</b>	Page	5	7
Modifi.Index	D		Name	Steinbach	22.11.06
Date	25.07.2013		Released		

#### **Safety instructions**

The gear unit may only be operated within the permissible limits indicated on the order specific operating and maintenance instructions and on page 2. Avoid any bodily contact with rotating parts. Maintenance work should only be carried out when the gearbox is at a standstill and cooled off. The motor must be disconnected.

The gear oil Shell Tivela WB used in the gear unit at the time of delivery, for which a safety data sheet is available, has the waste code 544 01 (synthetic coolants/lubricants).  
The grease Klüber Nontrop KR29 BBM450EP or Grafloscon C-SG 100 Ultra contained in the lubricator at the time of delivery, for which a safety data sheet is available, has the waste code 542 02 (grease waste/residues).

#### **Maintenance of safety-relevant components**

Good and durable lubrication provided, the spindle drive is designed for a service life of approx. 20,000 m. **Wear, if any, usually occurs at first at the threaded nut. It should therefore be included in the annual inspection. In the case of long operating times and high loads near the upper limit the unit should be inspected more frequently, preferably quarterly.** The amount of wear can be determined by measuring the distance between supporting nut and safety grip nut (dimension X on the drawing below). The original dimension at the time of delivery is noted on a name plate on the outside of the gearbox. For inspection remove the cap item 2. Do not remove the limit switch. If the distance has decreased/increased by 3.0 mm, the supporting nut must be replaced.

#### **Maintenance of the other gearbox components**

Spindle lubrication is ensured by the lubricator which is to be operated in accordance with the respective instructions. When the lubricator is empty it can be refilled and used again. At this occasion the spindle should be cleaned from old grease and greased again. Grease deposits in the protective tube and in the bellows are to be removed.

The gearbox is filled with oil. It should be regularly checked for leakages at the seams and the seals. If there are no leakages, it is sufficient to change the oil every 2 years. Capacity: 3.0 l.

A T L A N T A suggestion: Tivela WB from Shell.



# ATLANTA

## Documented Procedure

### BWL 070e

### 4100-001-12.93

Department	TB/Wes	<b>Operating and Maintenance Instructions Non-rotating trapezoidal thread spindle</b>	Page	6	7
Modifi.Index	D		Name	Steinbach	22.11.06
Date	25.07.2013		Released		

### Troubleshooting

The following information shall help you in the case of problems with your gear unit.

Problem	Cause	Remedy
Trapezoidal-thread spindle screeches		Turn off unit immediately and eliminate the cause.
	Lubricator empty	Refill lubricator, replace pressure chamber, replace battery.
	Emptying time chosen too long	Shorten emptying time (see lubricator instructions).
		Relubricate the spindle directly with a brush before starting up the unit again.
Motor current increases	Excessive load on spindle.	Check if the load or the distribution of the load has changed.
		Check moving parts and bearings of the machine for changes.
		Check if all parts move freely or are jammed.
	Insufficient lubrication of spindle.	Proceed as described under "spindle screeches".
Gear unit switches off.	Limit switch is actuated.	See "limit switch at grip nut" or "limit switch at protective tube".
	Motor switched off.	See "motor current increases".
Temperature on gearbox surface exceeds 60° C.	Excessive heat buildup between spindle and nut	See "motor current increases".
Limit switch at protective tube is actuated.	Overshooting of end position limit switch.	Check end position limit switch for proper function and position and replace, if necessary. Check wiring.
Limit switch at grip nut is actuated.	Supporting nut worn and safety grip nut engaged.	Send the gear unit to ATLANTA for replacement of supporting nut.



# ATLANTA

## BWL 070e

### Documented Procedure

### 4100-001-12.93

Department	TB/Wes
Modifi.Index	D
Date	25.07.2013

**Operating and Maintenance Instructions  
Non-rotating trapezoidal thread spindle**

Page	7	7
Name	Steinbach	22.11.06
Released		

**List of wear and spare parts of the basic gear unit:**

Qty.	Description	Item-No.	DIN	Dimensions	Code
2	Taper roller bearing	9 11 43 110	720	110x200x56	32 222
3	Radial shaft seal	9 21 93 150	3760	150x180x8.5	
2	Radial shaft seal	9 21 03 218	3760	110x130x12	
1	Deep groove ball bearing	9 11 05 040	625	20x72x19	6404
1	Deep groove ball bearing	9 11 04 050	625	25x62x17	6305
1	Deep groove ball bearing	9 11 04 060	625	30x72x19	6306
1	Deep groove ball bearing	9 11 02 110	625	55x90x18	6011
1	Deep groove ball bearing(2 rows)	9 11 07 070	625	35x80x31	4307
1	Angular contact ball bearing	9 11 17 006	628	30x72x30.2	3306
1	Radial shaft seal	9 21 03 128	3760	42x72x8	
1	Radial shaft seal	9 21 03 154	3760	55x90x10	

**Spare parts for lubricator 65 91 000:**

1	Pressure chamber	65 91 001			
1 kg	Grease: Klüber NONTROP KR29 BBM 450 EP	9 90 04 009			
1 kg	Grease: Klüber Grafloscon C-SG 1000 Ultra	9 90 04 018			

**Measuring the wear of the supporting nut:**

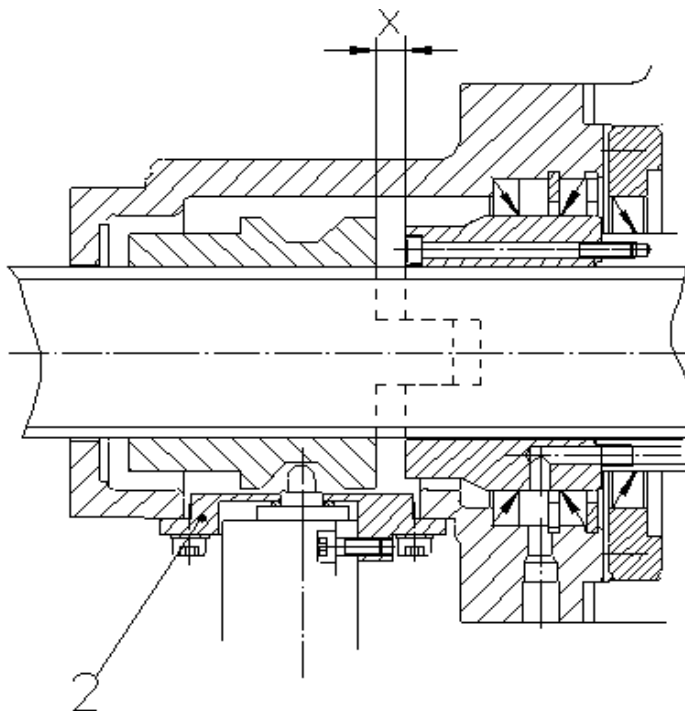



# ATLANTA

## Documented Procedure

### BWL 070e

### 4100-001-12.93

Department	TB/Wes
Modifi.Index	D
Date	25.07.2013

### Operating and Maintenance Instructions Non-rotating trapezoidal thread spindle

Page	8	7
Name	Steinbach	22.11.06
Released		

#### Circuit diagram:

